

Endurance Coach

Client Bike Fit Data Sheet

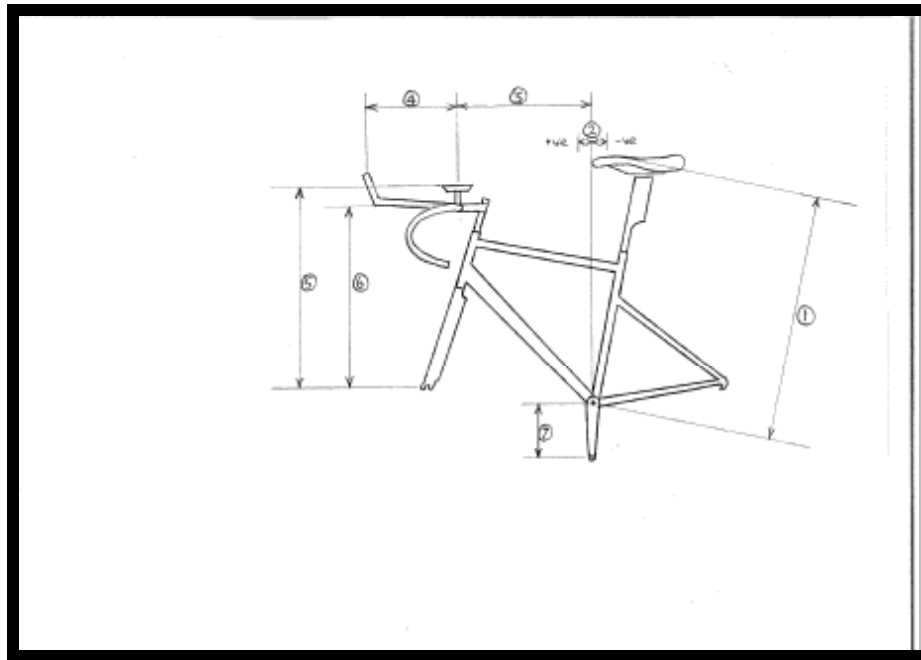

Bike Size Specifications

Number	Reference	Measurement & Date
1	Seat Height	
2	Seat Fore/aft	
3	Reach to pads	
4	Pad height	
5	Handlebar height	
6	Crank length	
	Cleat Position	

Notes/Recommendations:

Ensure to understand the common signs of the bike positioning needing some fine tuning, i.e. if your knees start to feel sore or your hamstrings feel not right etc. A professional bike fitter will ensure that you are made aware of all the key signs that the process is working.

Follow Up:

Feedback date:

Ensure that you make an appointment to go back and check with your bike fitter and provide some feedback on your new positioning.

Bike Record

Category	Date	By Whom	Changes Made	Cost
Bike Fit				
Bike Service				
Pre Round the lake Ride Check				
Pre 1/2 IM Check				
Pre IM Check				
Parts Replaced				

Bike Fit Measurements

Features	Measurement	Changes 1	Changes 2	Changes 3
Seat Height				
Seat Fore/aft				
Reach to Pads				
Pad Height				
Handlebar height				
Crank Length				
Cleat Position				

Training Points to Remember:

- 1.
- 2.
- 3.

Bike Feature	Bike Fit & Date	Measurement & Date
Seat Height		
Seat Fore/aft		
Reach to Pads		
Pad Height		
Handlebar height		
Crank length		
Cleat Position		
Notes:		

Follow Up:	Feedback date:
Feedback should include positive and negative comfort factors focusing on your ability to ride on aero bars for a length of time	